

A Simple Signal Canceller For 136Khz To Combat Loran or Other Noise Sources

by Derek Atter G3GRO

Prior to building this simple signal canceller, some experiments were carried out using an MFJ 1025 Signal Canceller Unit to cancel pulse sidebands from the Loran navigation system which spread into the 136 Khz LF band and often masks weak stations. By feeding signals from the main inverted “L” antenna together with the signals from a large vertical receiving loop (3 turns, approx 20ft by 20ft) into a twin channel up-converter with 10Mhz IF outputs and then into the MFJ1025, which is only designed to cover from 1.5Mhz to 30 Mhz, the Loran pulse sidebands can be completely nulled out leaving the DX stations in the clear and making a major improvement to my 136Khz receive capability not to mention the relief from not having to listen through the constant clatter of the Loran. I have also found the canceller system equally effective in dealing with a local noise source which has recently appeared just at dusk and which sounds as if it may be a defective sodium street light. As an experiment I have in fact built two loops at right angles, the plane of one loop running SW-NE favouring the Loran and the second running SE-NW for some experiments in comparing signals with different loop orientation. It should be noted that it is not practical at LF as it is at HF to produce a cardioid pattern using two nominally omni-directional wire antennas because at LF, the spacing would be small in terms of wavelength and hence there would be insufficient phase change with azimuth angle. It is the fact that there is a 180 degree phase change between signals arriving from opposite sides of the null at right angles to the plane of the loop that makes it possible to generate a cardioid pattern when signals are combined in the right proportions with those derived from an omni. The signal canceller based on the MFJ1025 has proved to be very flexible and effective but it is fairly complicated and having established what could be achieved in practice, I have now built a very simple cancellation system operating directly at 136Khz principally aimed at knocking out splatter from the Loran but also proving the capability of dealing with other sources of interference providing that they do not lie close to the bearing of the wanted signal! The canceller now feeds straight into the FT990 transceiver at 136Khz rather than through an up-converter.

The Canceller - A Poor Man's MFJ !

The basic 136 Khz canceller has only 5 passive components (See Figure 1 below). The signal from the omni-directional wire antenna feeds an adjustable

phase shifter with the output from the phase shifter being simply fed directly in parallel with the input from the loop antenna via an isolating variable resistor RV2 which controls the amount of omni-derived signal being combined with that from the loop. A change-over switch S1 at the input to the phase shifter allows a 180 degree phase shift to be added to that of the phase shifter. Capacitor C1 and variable resistor RV1 together with the tri-filar wound transformer form a variable phase-shifter with a range of approximately 180 degrees and reasonably constant amplitude over its control range. The variable phase control RV1 does not quite reach 0 degrees at one end of its travel and so switch S2 is provided which allows a fixed selection of the 0 degree position. This simple signal combiner arrangement is based on the premise that the signal from the inverted “L” will normally be much larger than that from the loop and thus allows the omni signal to be fed simply in parallel with the loop output from the phase-shifter via a reasonably high value of resistance in RV2. without adversely affecting the loop signal level. Adjusting the RV2 in conjunction with phase control RV1 allows the unwanted signal to be nulled out. In my case, the combined output of the loop and omni antennas from the canceller is then fed via a bandpass filter and 20dB amplifier to the receiver input of the FT990. It is also useful to be able to switch off the omni or loop inputs individually via S3/S4

The RX Preamplifier

Most general coverage receivers tend to be somewhat short of gain at LF and although the signal from the main LF antenna was adequate, I found that even a relatively large loop needed some additional gain in order to provide sufficient signal level from the Loran to allow cancellation to be effective. With some receivers, the preamp may not be necessary but any preamplifier should have a low intrinsic noise figure to avoid adding additional unwanted thermal noise to the omni signal and hence degrade the overall noise performance. The preamplifier I have been using has two stages of amplification and is preceded by a bandpass filter. The bandwidth of the input bandpass filter is about 3.5 Khz. Switch S5a/S5b is an optional facility which allows the bandpass filter to be replaced by a low-pass filter with a 3dB cut-off frequency of around 180 Khz so that the preamp can be used from a few Khz up to above 200Khz for general LF use. The preamp uses two MAR3 Minicircuits “Modamps” in series which each have a gain of 12dB and -1dB saturation point of +10dBm plus a good noise figure. They also have a nominal input impedance of 50 ohms. The choice of two MAR3 gain-blocks rather than a single MAR6 with a similar total gain, was dictated by the better signal handling capability of the MAR3. I have in practice found the signal handling of the latter very good even with a wide open front-end. The -3dB bandwidth of the

input bandpass filter can be adjusted to approximately 3.5 KHz by means of the small top coupling trimmer capacitor VC1 between coil L1 and L2 to give a flat top response or slightly over-coupled double hump response after first peaking the cores of L1/L2. with loose coupling. Diodes D1/D2 at the input protect against unwanted TX power.

Performance

The nulling performance of the simplified system appears to be similar to that of the more complicated earlier version using the MFJ1025. The Loran interference produces the equivalent of around 15 microvolts (+24dbuV) without the nulling system in operation giving an S meter reading of S4/S5 on the FT990. This can be nulled quite smoothly down to below the prevailing general local noise which during the day averages at around S1 on the S meter (around about 1 microvolt) or less with of course the occasional kicks and clicks etc. on the S meter from time to time. A strong carrier for example (eg. DCF39, the German RTTY station on 138.8 KHz) can be nulled by typically 30 dB but the phase and amplitude controls then become quite critical to achieve that depth of null. If one wishes to use canceller on very strong carriers etc. it may be beneficial to split the amplitude adjustment RV2 into separate coarse and fine controls. Avoid wire-wound potentiometers. Some random variability has been observed in the depth of deep nulls during periods of high winds which is thought to be due to phase changes arising from the slight de-tuning effects as the wire antenna swings in the wind but does not have any significant practical effect the cancellation of Loran etc. With the canceller system in use I have been able in recent weeks to copy weakish DL/HB9 stations etc. with relative ease whereas without it, I would not even have detected the signal or have extreme difficulty in copying. Fortunately, from my location in Sussex (IO91VC), there is currently no DX activity on the same heading as the Loran station which of course would also be nulled out!

The Antennas

The main transmitting antenna being used at the moment to provide the omnidirectional input to the canceller system is a base-loaded inverted "L" with the vertical section of around 36ft and a 3-wire top loading capacitance of 3 parallel wires each of 150ft strung between spreaders at each end. The above antenna feeds the canceller system via the transmit-receive switching relay.

The 20ft square loop antenna used to cancel Loran is strung between trees about 25 feet beyond the end of the main transmitting antenna and uses reasonably thick (1.5mm²) stranded insulated wire to keep the RF losses low. The individual turns of the loop are just bunched together and suspended at each corner via an insulator. The loop is resonated by two capacitors in series across the loop mounted at the centre of the lower leg providing capacitive tap matching to the output coax. The "bottom" capacitor is 47N in parallel with 10N across the 50 Ohm feeder; the "top" capacitor has a value of 7.65N made up of several individual capacitors in parallel one of which is a 500pf compression trimmer. The capacitors are mounted in one of the small sealed kitchen food storage containers. The loop may be tuned to resonate at 137KHz by injecting a signal generator into the 50ohm output port and connecting an oscilloscope or RF millivoltmeter across the loop via a high impedance probe and adjusting the capacitance for resonance.

I have added a slight complication in my version of the loop interface box to include a small 12v relay and RF choke to allow DC to be fed down the coax cable to the loop so that the second loop running at right-angles can be remotely selected from the shack in the house some 150ft away.

My experience with smaller multi-turn loops of around 1 metre square has been somewhat disappointing in receiving DX stations by comparison with the main inverted "L" antenna nor did I seem able to obtain sufficient signal from the Loran sidebands to adequately cancel the Loran hence my use of a larger loop . However this may have been due to shadowing from the large wire transmitting antenna and if it is not practical to put up a larger loop then it may be worth investigating a smaller multi-turn loop in other sites.

Ref #1 : Crawley Club Newsletter, December 1998.

Ref #2 : CARC Website < <http://www.btinternet.com/~raheesom/carc/index.htm>>

G3GRO FEB19 1999

FIGURE 1
BASIC CANCELLER

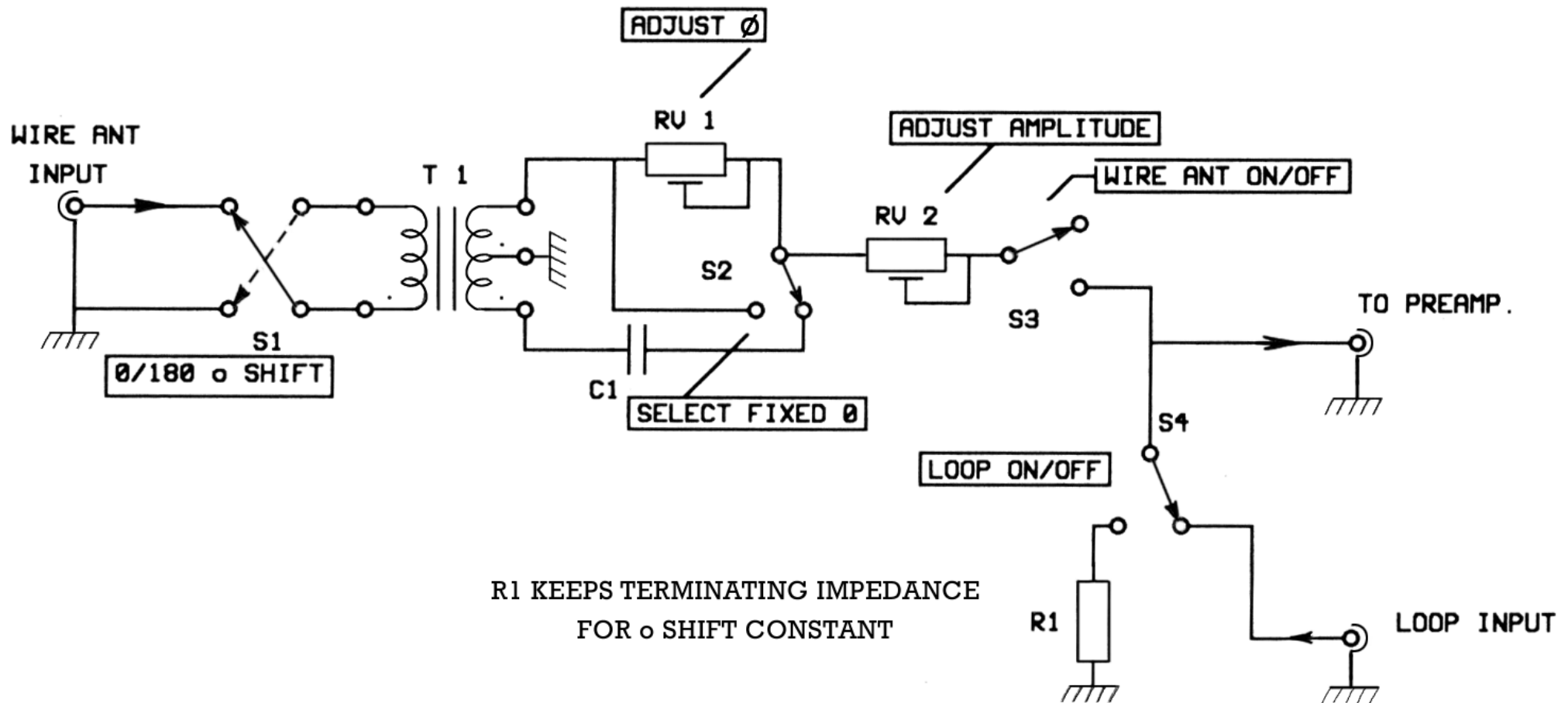

S1: 2 POLE C.O. MINATURE TOGGLE
 S2 S3 S4: 1 POLE C.O.
 C1: 22n
 RV1: 500R
 RV2: 1K

LINEAR CERMET
 OR CARBON

R1: 47R
 T1: TRIFILAR WOUND TOROID 3x18 TURNS
 28 OR 32 SWG ON FERRITE CORE
 13.25mm DIA, C85 MATERIAL (PHILIPS)
 OR 'FAIRITE' FT-50A-43 CORE ETC.

NOTE: S2 S3 & S4 ARE NOT ESSENTIAL BUT ADD OPERATING CONVENIENCE.

FIGURE 2
RX PREAMPLIFIER

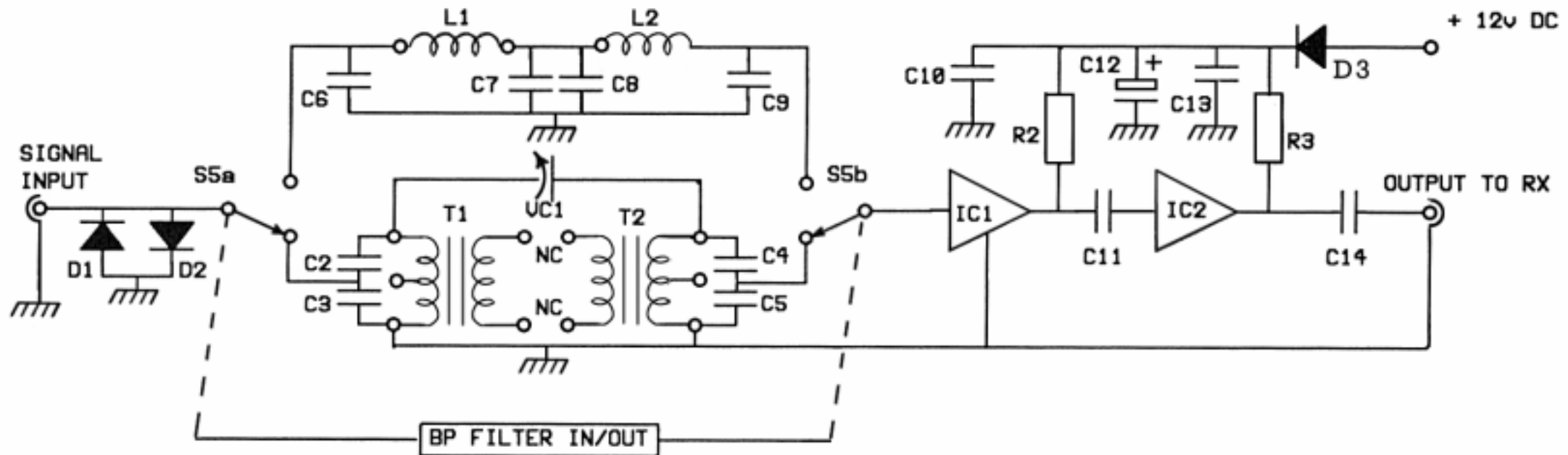

D1, D2: 1N4948
 D3: 1N4001 ETC
 S5: 2 POLE C.O.
 MINIATURE TOGGLE
 T1, T2: TOKO 3.5mH CAN 1A350EK
 RED CORE
 L1, L2: 68uH TOKO 283AS-680

C2, C4: 330pF
 C3, C5: 4.7n
 C6, C7, C8, C9: 22n
 C10, C11, C13, C14: 100n
 C12: 47uF Electrolytic
 R2, R3: 220R0.25W
 VC1: 10pF TRIMMER
 IC1, IC2: MAR3